

S
A
F
E
T
Y
&
R
I
S
K
M
A
N
A
G
E
M
E
N
T

SAFETY BASICS *Healthcare Series*

Bathtub, Shower and Toileting

Activity: Resident Handling

Description: Toilet seat risers

When to Use: For toileting partially weight bearing residents who can sit up unaided, use upper extremities (have upper body strength), are able to bend hips, knees and ankles, and are cooperative. Independent residents can also use these devices.

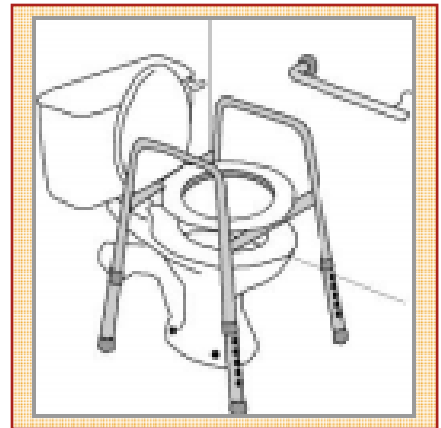

Points to Remember: Risers decrease the distance and amount of effort required to lower and raise residents. Grab bars and height-adjustable legs add safety and versatility to the device. Ensure device is stable and can accommodate resident's weight and size.

Safety Basic Health Care Series Information is extracted directly from OSHA safety materials. For additional information consult www.OSHA.gov